

General Description

The YB4042 is a highly integrated Power Bank IC with a Linear Li-Ion Charger up to 1A charge current and step-up converter designed for driving up to 27 white LEDs (9 strings of 3 LEDs each) from a 4.2V system rail. With few external components, the YB4042 could enable Charger and LED driver and is well suited for portable power bank applications.

Features

- Up to 1A Programmable Battery Charging Current
- Automatic Recharge
- Very Low Shutdown-Mode I_{BAT} Current
- Thermal Protection
- Constant-Current/Constant-Voltage operation with thermal regulation to maximize Rate Without risk of overheating
- Preset 4.2V charge voltage with $\pm 1\%$ accuracy
- C/10 charge termination
- 2.8V trickle current charge threshold
- Drives up to 27 White LEDs
- Up to 92% Boost Conversion Efficiency
- Over 1.2MHz Fixed Switching Frequency
- Low 250mV Feedback Voltage
- Soft-Start/PWM Dimming
- Internal 1.6A Current Limit
- Available in SOP8-PP package

Applications

- Portable Power Bank Applications

Typical Application Circuit

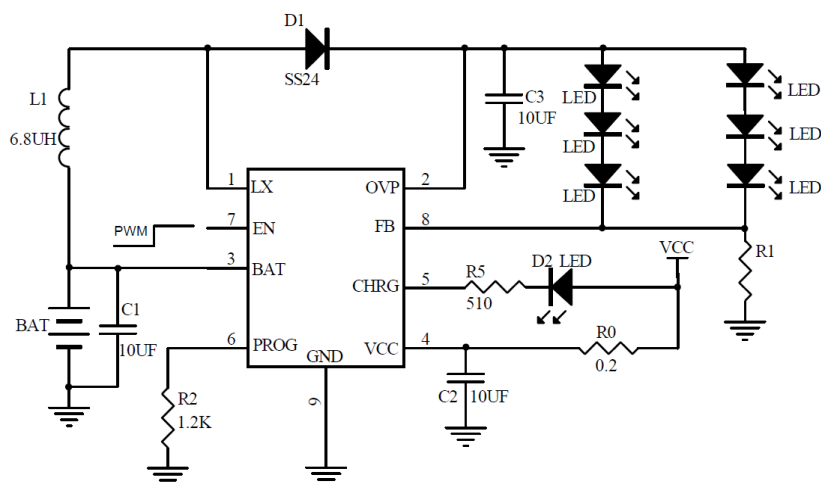

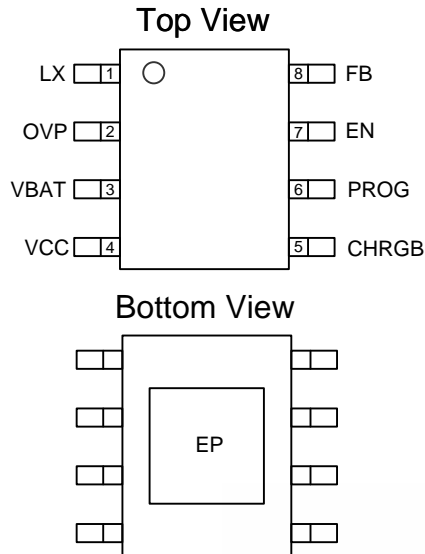
Pin Descriptions SOP-8L (EP)

Name	No.	I / O	Description
LX	1	I	Switch Output. Connect this pin to the inductor.
OVP	2	P	Over Voltage Input. OV measures the output voltage for open circuit protection.
VBAT	3	I	Battery Voltage
VCC	4	P	Supply Voltage
CHRGB	5	I	Charging Indicator
PROG	6	O	CC Charge Current Setting & monitor
EN	7	I	Regulator On/Off Control Input.
FB	8	P	Feedback Input. The FB voltage is 0.25V. Connect a resistor divider to FB.
EP	9	P	IC Ground , Exposed PAD-Must connect to Ground

Battery Charging Status Indicators

Charge Status	CHRGB (Red Light)
In Charging	ON
Charge Termination	OFF

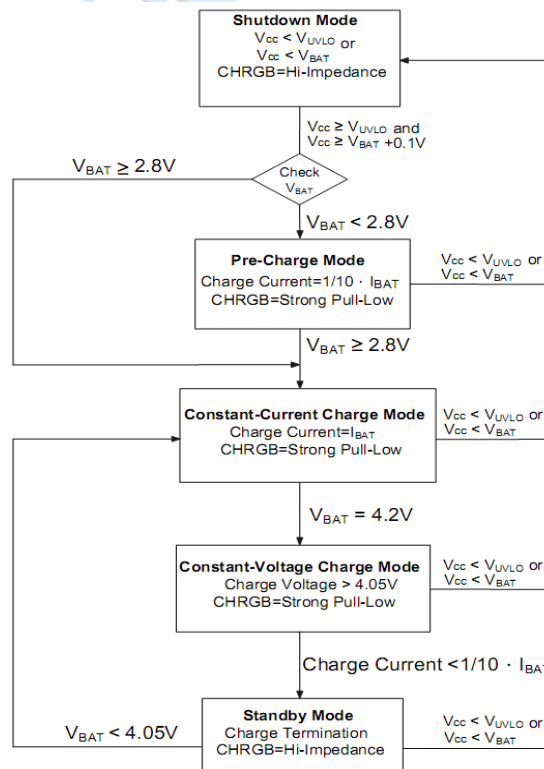
Battery Charging State Diagram

Function Block Diagram

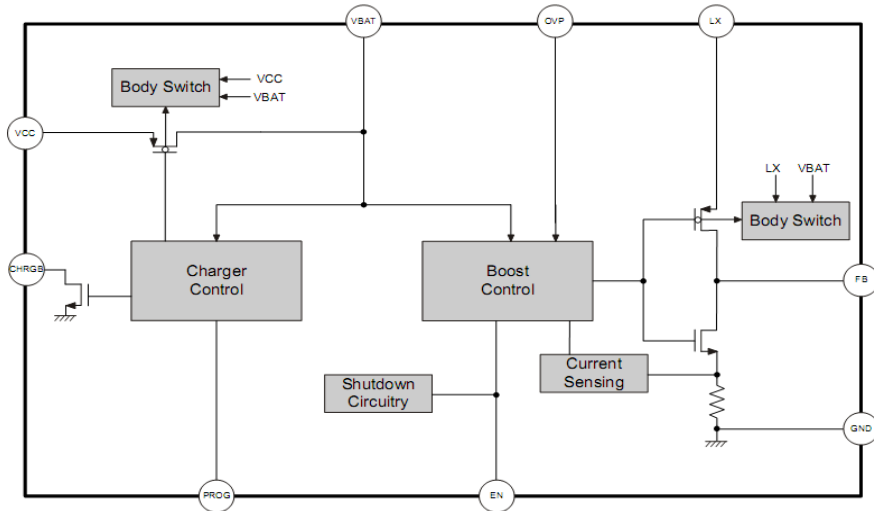

Ordering Information

Part Number	Operating Temperature	Package	MOQ	Description
YB4042	-40°C ~ +85°C	SOP-8L(EP)	3000	Tape & Reel

Absolute Maximum Ratings

Parameter	Symbol	Conditions	Min.	Typ.	Max.	Unit
Supply Voltage	V_{IN}		-0.3		6	V
EN Voltage	V_{EN}		-0.3		$V_{BAT}+0.3$	V
LX Voltage	V_{LX}		0		30	V
All Other Pins			-0.3		6	V
BAT Pin Current	I_{BAT}				1.2	A
Junction Temperature	T_J				+150	°C
Storage Temperature	T_S		-65		+150	°C
Thermal Resistance	θ_{JA}	SOP-8L(EP)			60	°C / W
	θ_{JC}				10	°C / W
Operating Temperature			-40		+85	°C
Lead Temperature (Soldering, 10 Sec)					+260	°C

Power Bank IC with 1 A Linear Charger and 30V Boost LED Driver

Recommended Operating Conditions

Parameter	Symbol	Conditions	Min.	Typ.	Max.	Unit
Supply Voltage	V_{IN}		4.5		5.5	V
Booster Operation Supply Voltage	V_{BAT}		2.8		4.4	V
Operating Temperature		Ambient Temperature	-40		85	°C

DC Electrical Characteristics ($V_{IN}=5V$, $T_A=25^\circ C$, unless otherwise noted)

Parameter	Symbol	Test Conditions	Min.	Typ.	Max.	Unit
V_{IN} Standby Current	$I_{VIN,STB}$	Charge Termination		600		μA
V_{IN} Shutdown Supply Current	$I_{VIN,SHDN}$	$V_{IN} < V_{BAT}$, $V_{IN} < V_{ADP,UV}$ $V_{BAT} < V_{BAT,UV}$		50		μA
BAT Pin Current	I_{BAT}	$R_{PROG}=2.3K$	450	500	550	mA
		$R_{PROG}=1.1K$	900	1000	1100	mA
		Standby-Mode, $V_{BAT}=4.2V$	0	-6	-15	μA
		Shutdown-Mode		± 6	± 10	μA
BAT CV Output (Float) Voltage	V_{FLOAT}	$0^\circ C < T_A < 85^\circ C$	4.158	4.2	4.242	V
V_{IN} Charge Under Voltage Lockout Threshold	$V_{IN,UV}$	V_{IN} Rising	3.5	3.7	3.9	V
V_{IN} Charge Under Voltage Lockout Threshold Hysteresis	$V_{IN,UVHYS}$			500		mV
$V_{IN}-V_{BAT}$ Charge Lockout Threshold	V_{ASD}	V_{IN} Rising		120		mV
		V_{IN} Falling		10		mV
C/10 Charge Termination Current Threshold	I_{TERM}	$R_{PROG}=1.1K$		100		mA
CHRGB Pin Output Low Voltage	V_{LED}	$I_{LED}=5mA$		0.35	0.6	V
Battery Recharge Threshold Voltage	V_{RECHRG}	$V_{FLOAT}-V_{RECHRG}$		120		mV
Recharge Comparator Filter Time	T_{RECHRG}	V_{BAT} High to Low		0.8		mS
C/10 Charge Termination Comparator Filter Time	T_{TERM}	I_{BAT} Falling below I_{TERM}		0.8		mS
Booster Operation Supply Range	V_{BAT}		2.8		4.4	V
Booster Under Voltage Lockout	$V_{BAT-UVLO}$			2.2		V
Under Voltage Lockout Hysteresis				0.1		V
Booster Operation Frequency	F_{OSC}		1.0	1.2	1.4	MHz
Regulated Feedback Voltage	V_{FB}	$-40^\circ C < T_a < 85^\circ C$	0.237	0.25	0.263	V
Rds(ON) of N-channel FET		$I_{SW} = -100mA$		80	150	m Ω
LX Leakage Current		$V_{EN} = 0V$, $V_{LX} = 0V$ or $5V$ $V_{BAT} = 4.2V$			1	μA
Thermal Shutdown	T_{LIM}			150		°C
EN Enable Voltage	$V_{EN,H}$		1.3			V
EN Shutdown Voltage	$V_{EN,L}$				0.4	V
OVP Threshold	V_{ovp}	OVP Threshold		28		V

Typical Operating Characteristics

(Charger : $V_{CC}=5V$, $T_A= 25^{\circ}C$, unless otherwise noted)

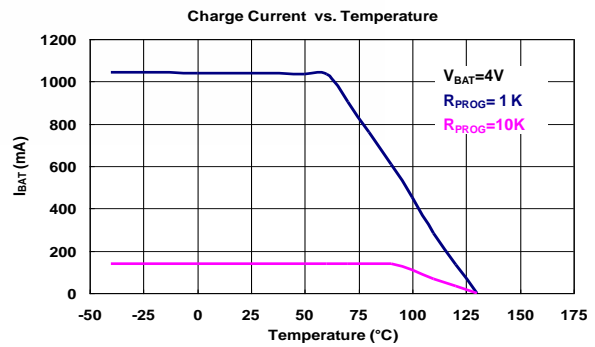
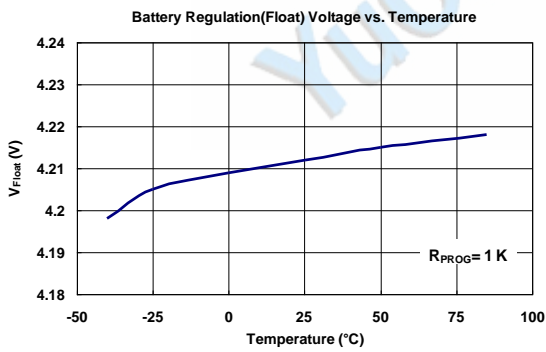
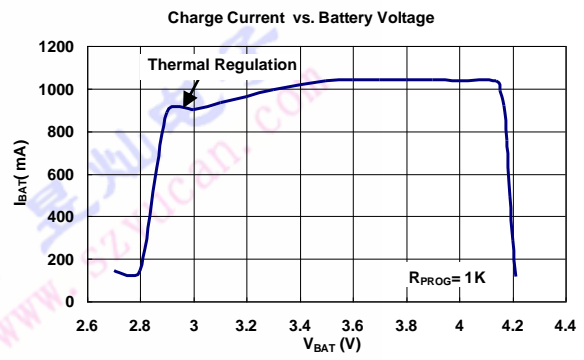
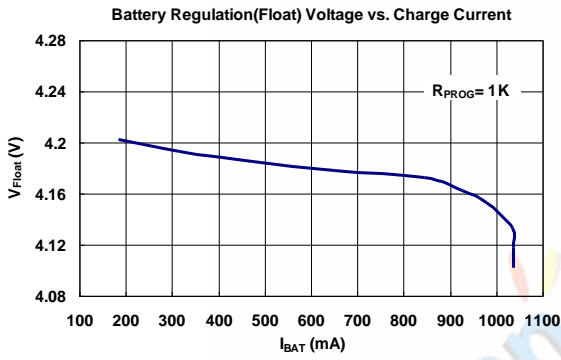
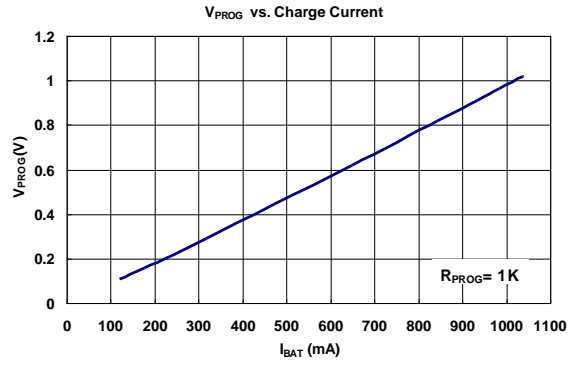
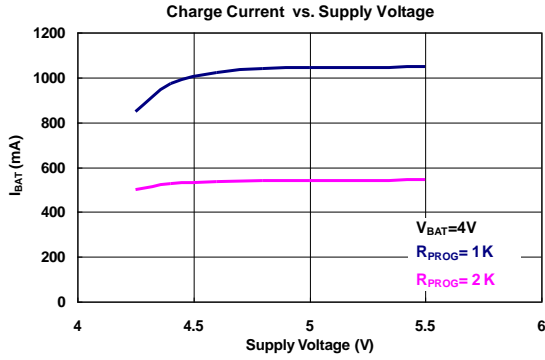

Power Bank IC with 1 A Linear Charger and 30V Boost LED Driver

(Boost : $V_{BAT}=4.2V$, Driver 27 LDEs , $T_A= 25^{\circ}C$, unless otherwise noted)

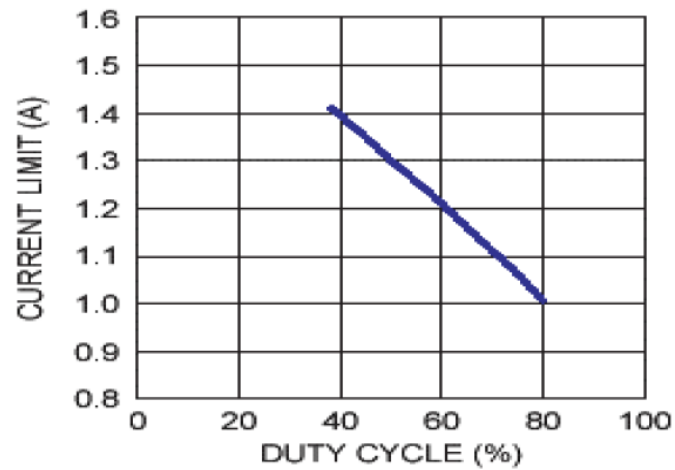
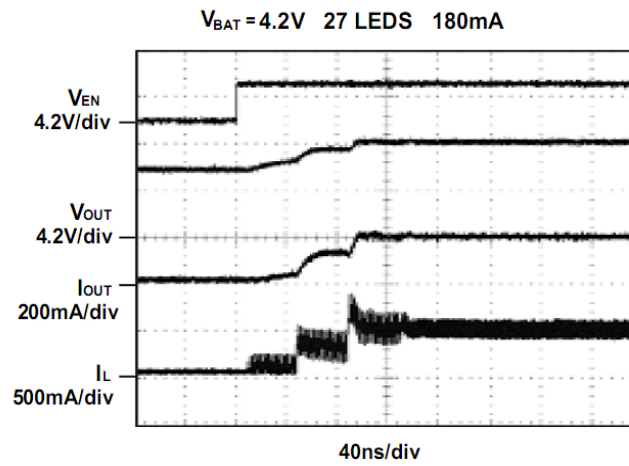
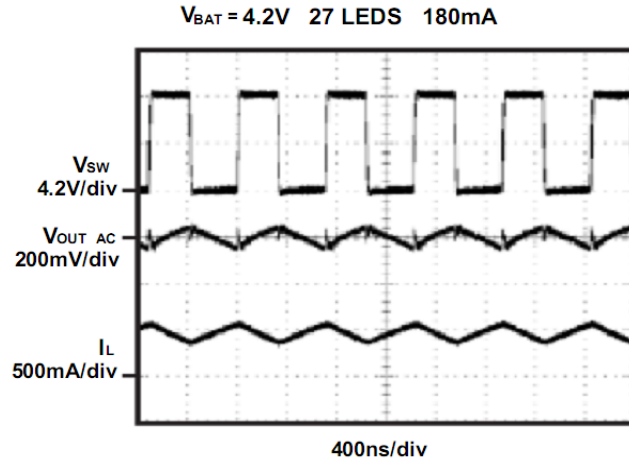

Function Description

For Battery Charging

Operation

The YB4042 is with a linear battery charger designed primarily for charging single cell lithium-ion battery. The charger uses a constant-current/constant-voltage charging algorithm with programmable current. Charging current can be programmed up to 1A by an external single resistor. The YB4042 includes an internal P-channel power MOSFET and thermal regulation circuitry. No blocking diode or external sense resistor are required. Thus, the basic charger circuit requires only two external components. Furthermore, The YB4042 is capable of operating from a USB power source.

Normal Charge Cycle

A charge cycle begins when the voltage at the V_{IN} pin rises above the UVLO threshold. If the BAT pin voltage is smaller than 2.8V, the charger enter trickle charge mode. In this mode, the YB4042 supplies approximately 1/10 the programmed charging current to bring the battery voltage up to a safe level for full current charging. When the BAT pin voltage rises above 2.8V, the charger enters constant-current mode, where the full programmed charge current is supplied to the battery. When the BAT pin approaches the final float voltage (4.2V), the YB4042 enters the constant-voltage mode and the charge current begins to decrease. When the charge current drops to 1/10 of the programmed value, the charge cycle ended.

Programming Charge Current

The charge current is programmed by a single resistor connected from the PROG pin to ground. The battery charging current is 1150 times the current flowing out of the PROG pin. The required resistor value can be calculated from the charge current with following equation:

$$R_{PROG} = \frac{1150}{I_{CHG(MAX)}}$$

The instantaneous charging current may differ from above equation in trickle or constant voltage modes. The instantaneous charging current provided to the battery can be determined by monitoring the PROG pin voltage at any time with the following equation:

$$I_{CHG} = \frac{V_{PROG}}{R_{PROG}} \times 1150$$

Charge Termination

A charge cycle is terminated when the charge current falls to 1/10 the programmed value after the final float voltage is reached. The charge current is shut off and the YB4042 enters standby mode, where the input supply current drops to 55 μ A. The YB4042 draws very few current from the battery in standby mode. This feature reduces the charge and discharge cycles on the battery, further prolong the battery life.

Thermal Protection when charging

An internal thermal feedback loop reduces the fixed charge current if the die temperature rises above a preset value of approximately 100°C. This feature protects the YB4042 from excessive temperature and allows the user to push the limits of the power handing capability of a given circuit board without risk of damaging the YB4042. The charge current can be set according to typical ambient temperature with the assurance that the charge will automatically reduce the current in worst case condition.

V_{IN} under Voltage Lockout (UVLO)

An internal under voltage lockout circuit monitors the input voltage and keeps the charger in shutdown mode until V_{IN} rises above the under voltage lockout threshold. The UVLO circuit has a built-in hysteresis of 500mV. Furthermore, to protect against reverse current in the power MOSFET, the UVLO circuit force the YB4042 to enter shutdown mode if V_{IN} falls to within 10mV of the battery voltage. If the UVLO comparator is tripped, the charger will not come out of shutdown mode until V_{IN} rises 100mV above the battery voltage.

Automatic Recharge

Once the charge cycle is terminated, the YB4042 continuously monitors the voltage on the BAT pin using a comparator with a 0.8ms filter time (T_{RECHARGE}). A charge cycle restarts when the battery voltage falls below 4.05V (which corresponds to approximately 80% to 90% battery capacity). This ensures that the battery is kept at or near a fully charged condition and eliminated the need for periodic charge cycle initiations. CHRGB output enters a strong pull-down state during recharge cycles.

For Booster LED Driver

NORMAL OPERATION

The YB4042 uses a constant frequency, peak current mode boost regulator architecture to regulate the strings of white LEDs. At the start each oscillator cycle the FET is turned on through the control circuitry. To prevent sub-harmonic oscillations at duty cycles greater than 50%, a stabilizing ramp is added to the output of the current sense amplifier and the result is fed into the positive input of the PWM comparator. When this voltage equals the output voltage of the error amplifier the power FET is turned off.

The voltage at the output of the error amplifier is an amplifier version of the difference between the 250mV reference voltage and the feedback voltage. In this way the peak current level keeps the output in regulation. If the feedback voltage starts to drop, the output of the error amplifier increases. This results in more current flowing through the power FET, thus increasing the power delivered to the output.

Setting the LED Current

The LED current is controlled by the feedback resistors R1, The current through the LEDs is given by the equation:

$$I_{LED} = 250mV/R1$$

Analog and Digital Dimming

There are three methods to control dimming for the YB4042 during normal operation. The first method uses DC voltage to control the feedback voltage. As the DC voltage increases, current starts flowing down R1, R2 and R3. The loop will continue to regulate the feedback voltage to 250mV. Thus the current has to decrease through the LEDs by the same amount of current as is being injected from the DC voltage source. With a V_{DC} from 0V to 2V, the resistor values shown for R2 and R3 can control the LED current from 0mA to 20mA.

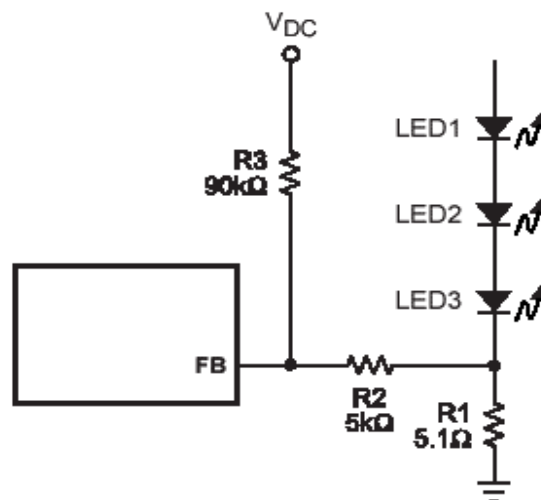

Power Bank IC with 1 A Linear Charger and 30V Boost LED Driver

Other applications require a logic signal to control dimming. The PWM signal is applied to the EN pin of the YB4042. The LEDs will switch between full load to completely shut off. The average current through the LEDs will increase proportionally to the duty cycle of the PWM signal used in should be 200KHz or below due to the soft-start function.

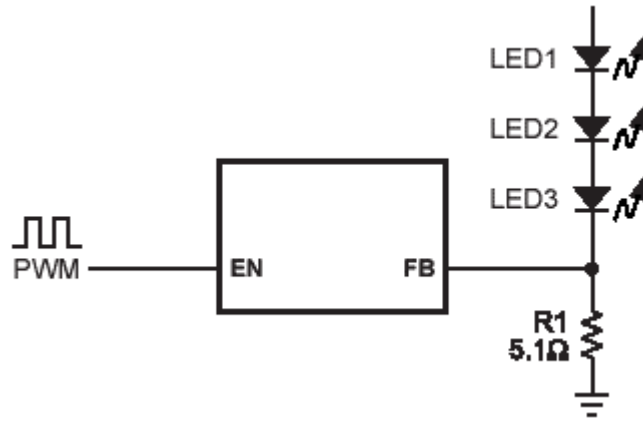

Open Load Protection

Open load protection will shut off the YB4042 if the output voltage rises too high when the OVP pin is tied to the output. In some cases an LED may fail. This will result in the feedback voltage always remaining at zero.

The part will run at maximum duty cycle boosting the output voltage higher and higher. By tying the OVP pin to the top of the LED string the YB4042 can check for this condition. If the output exceeds 28V, the YB4042 will shut down. The part will not switch again until the power is recycled.

Board Layout Considerations

Because of the small size of the SOP-8L(EP), it is very important to apply a good thermal conduction PC board layout to maximize the available charge current. The thermal path for the heat generated by the IC is from the die through the package leads(especially the ground lead) to the PC board copper. The PC board copper is the heat sink. The copper pads footprint should be as large as possible and expand out to large copper areas to spread and dissipate the heat to the surrounding ambient. Feed-through vias to inner or backside copper layers are also useful in improving the overall thermal performance of the charger. Other heat source on the board, not related to the charger, must also be consider when designing a PC board layout because they will affect overall temperature rise and the maximum charge current.

V_{IN} Bypass Capacitor

Many types of capacitors can be used for input bypassing, however, caution must be exercised when using multilayer ceramic capacitors. Because of the self-resonant and high Q characteristics of some types of ceramic capacitors, high voltage transients can be generated under some start-up conditions, such as connecting the charger input to a live power source. Adding a 0.3Ω resistor in series with an X5R ceramic capacitors (as shown in Figure 1) will minimize start-up voltage transients.

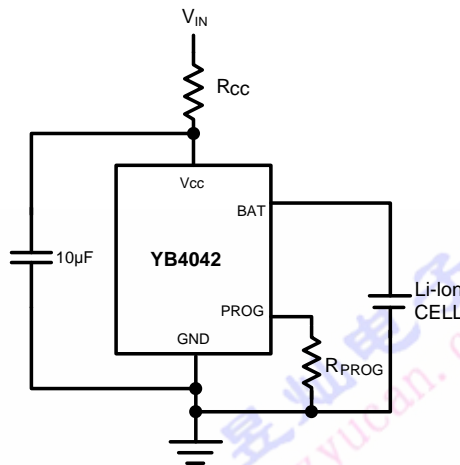
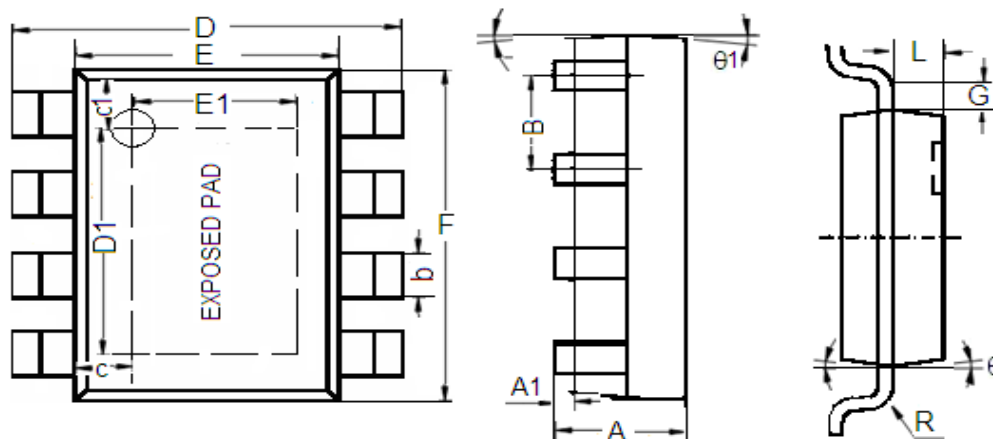

FIGURE 1

Package Outline

SOP-8L (EP)



Character	Dimension (mm)		Dimension (Inches)	
	Min	Max	Min	Max
A	1.350	1.750	0.053	0.069
A1	0.1	0.3	0.004	0.012
B	1.27(Typ.)		0.05(Typ.)	
b	0.330	0.510	0.013	0.020
c	0.9(Typ.)		0.035(Typ.)	
c1	1.0(Typ.)		0.039(Typ.)	
D	5.8	6.2	0.228	0.244
D1	3.202	3.402	0.126	0.134
E	3.800	4.000	0.150	0.157
E1	2.313	2.513	0.091	0.099
F	4.7	5.1	0.185	0.201
L	0.675	0.725	0.027	0.029
G	0.32(Typ.)		0.013(Typ.)	
R	0.15(Typ.)		0.006(Typ.)	
θ1	7°		7°	
θ	8°		8°	